



CONKLIN BAY NAMING OPPORTUNITIES

June 2020

	<p>Overlook #1 - \$60K (large one) or 4 @ \$15K</p> <ul style="list-style-type: none">• \$50K + \$10K for maintenance• Attach a plaque to the post with informational sign
	<p>Overlook #2 - \$30K or 2 @ \$15K</p> <ul style="list-style-type: none">• \$25K + \$5K for maintenance• Attach a plaque to the post with informational sign
	<p>Overlook #3 - \$30K or 2 @ \$15K</p> <ul style="list-style-type: none">• \$25K + \$5K for maintenance• Attach a plaque to the post with informational sign



**Overlook #4 - \$30K
or 2 @ \$15K**

- \$25K + \$5K for maintenance
- Attach a plaque to the post with informational sign



**Bollard - \$20K
or split 8 @ \$2,500**

- Place a plaque in ground by the post with informational sign



Bike Repair Station - \$1K

- Includes a high-quality vinyl decal (plaques are more difficult because of curved surfaces)

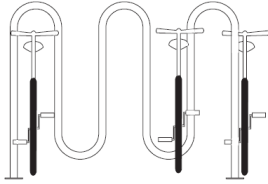

Parking Bicycles

Bikes can be parked as illustrated.

- Under "waves"
- Over "waves" (front tire straddling lower wave).
- On each end.

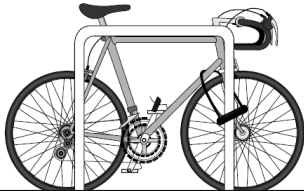

Parking Bicycles

Bikes can be parked as illustrated, on both sides of the unit.

Bike Rack - \$500

- Three bike racks are available
- Includes a high-quality vinyl decal (plaques are more difficult because of curved surfaces)



Dog Waste Stations - \$500

- Two Stations needed
- One is already secured
- Includes a plaque



Pavers \$300

- 4" x 8" Paver
- Along concrete section
- Form to fill out

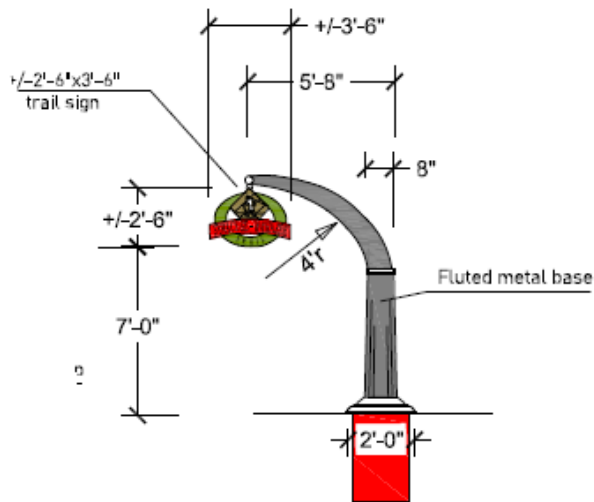

Arch Post at Entrance to Boardwalk TBD

Donor Wall TBD

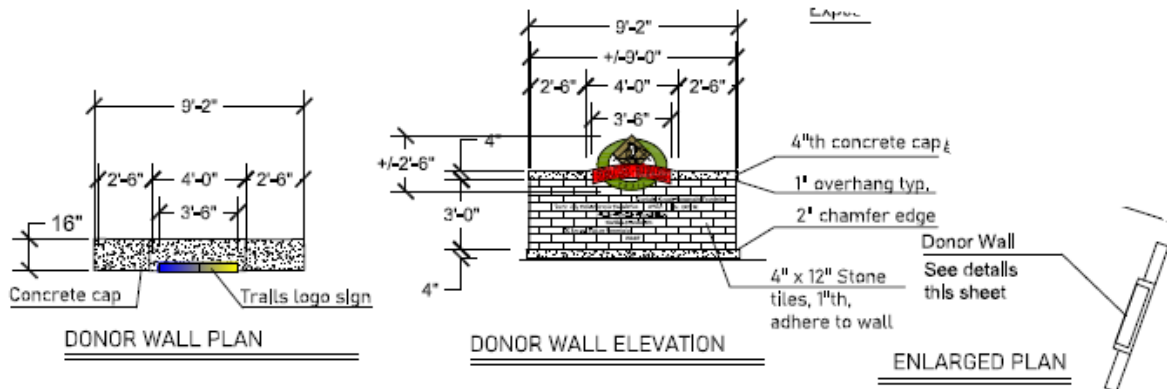



Artwork at entrance to Conklin Bay TBD

- Huge boulder or rock with artwork.
- Art contest?